

EUROMAP 75-2	<p>Protocol for Communication with Peripheral Equipment</p> <p>Demands on EUROMAP 75 Devices</p>
---------------------	---

Version 1.1, July 2010
14 pages

This recommendation was prepared by the Technical Commission of EUROMAP.

History

Date	Changes
May 2010	Document published
July 19, 2010	Clause 1.4 "References" updated

Contents	Page
History	2
1 Introduction	4
1.1 Purpose	4
1.2 Scope	4
1.3 Definitions, acronyms and abbreviations.....	4
1.4 References	4
1.5 Document Overview	4
2 Demands on EUROMAP 75 devices	5
2.1 Physical layer	5
2.1.1 M12 connector.....	5
2.1.2 Hybrid-cable	6
2.2 Wiring concept.....	7
2.2.1 RT (realtime Ethernet) Network.....	7
Figure 1: RT Network – Example of a line topology (daisy chain).....	8
Figure 2: RT Network – Example of a ring topology	9
Figure 3: RT Network – Example of a star topology	10
2.2.2 EUROMAP 75 cable.....	11
Figure 4: EUROMAP 75 cable – “isolated” wiring.....	11
Figure 5: EUROMAP 75 cable – “not isolated” wiring.....	12
Figure 6: Example of a hybrid-cable	13

1 Introduction

Please note:

When applying EUROMAP 75 please check in your quotation or machine documentation, if there is marked which Ethernet System is used for the device profile.

1.1 Purpose

This document describes the profile for EUROMAP 75 measuring amplifiers.

1.2 Scope

The EUROMAP 75 specification is divided into a general description, the device profile, a definition of the interface between the injection moulding machines and signal converters and the implementation of different (Realtime-) Ethernet Systems. The present part of document describes the demands on EUROMAP 75 devices, the physical layer and the wiring concept.

1.3 Definitions, acronyms and abbreviations

EUROMAP	European Committee of Manufacturers of Plastics and Rubber Machinery (http://www.euromap.org/).
CiA	CAN in Automation. Organization responsible for the definition of different CAN protocols, a.o. CAN Application Layer (CAL) and CANopen (http://www.can-cia.de/).
CAL	CAN Application Layer. Communication mechanisms standardized by CiA for CANbased systems (DS 201..207).
CANopen	Communication profiles (DS 301) and device profiles (CiA DS 40x) based on CAL, standardized by CiA.

1.4 References

<u>Short name</u>	<u>Title</u>	<u>Version</u>	<u>Autor</u>
EUROMAP 75	EUROMAP 75-1 "Protocol for Communication with Peripheral Equipment - Device Profile for Measuring Amplifiers"	1.1	EUROMAP
	EUROMAP 75-2 "Protocol ... - Demands on EUROMAP 75 Devices"	1.1	
	EUROMAP 75-3 "Protocol ... - Implementation of Different Realtime Ethernet Systems"	1.2	
CiA DS-102	CAN Physical Layer for Industrial Applications	2.0	CiA
CiA DS-301	CANopen Application Layer and Communication Profile	4.0	CiA
CiA DSP-404	Device Profile for Measuring Devices and closed-loop controllers	1.0	CiA

1.5 Document Overview

This document is divided into:

- Physical layer
- wiring concept

2 Demands on EUROMAP 75 devices

2.1 Physical layer

Recommended is the use of two 8-pin M12 connectors, with the pinning according to the EUROMAP 75 - M12 interface specification for 24V/2A peripheral devices.

2.1.1 M12 connector

- The following signals are used:

Pin 2	TD+	Transmission Data +	orange/white
Pin 3	TD-	Transmission Data -	orange
Pin 5	RD+	Receiver Data +	green/white
Pin 6	GND	Ground 24V DC	blue
Pin 7	+24V	Power supply 24V DC	brown
Pin 8	RD-	Receiver Data -	green

- Shielding on connector housing
- The master/manager node has a female connector
- All devices (peripheral equipment) have two connectors:
 - one bus-in connector, A-coding, M12-male
 - one bus-out connector, A-coding, M12 female

Also recommended is the use of a hybrid-cable, according to the EUROMAP 75 - M12 interface specifications.

2.2 Wiring concept

2.2.1 RT (realtime Ethernet) Network

Ethernet devices are wired as a bus. The wiring system used, line topology (daisy chain), ring topology or star topology, is dependent on the RT Ethernet system applied in each case.

- The injection moulding machine is the only source of 24 V energy for the complete network, i.e. connected EUROMAP 75 peripheral equipment never feeds into the 24 V power supply.
- The 24 V power supply is to be conducted in accordance with the standard IEC1131.
- The maximum load capacity per machine outlet (source) is 2A. If the sum of connected equipment exceeds the limit of 2A an additional machine outlet is to be used. The topology of the network is to be adapted accordingly.

GND concept of the machine connection:

- The M12 sockets (screened) on the injection moulding machine have a low-impedance connection to the machine ground.
- The GND cable of the 24V supply is always connected to the machine ground with low-impedance.

GND concept of the peripheral equipment:

- The supply cables +24V and GND are connected through to the peripheral device from the M12 connector (BUS IN) to the M12 socket (BUS OUT). This connection must have an ampacity of at least 2A.
- The screened M12 connector (BUS IN) and the screened M12 socket (BUS OUT) are connected together with low impedance.
- Preferably, the screened M12 plug connector and the housing of the peripheral device are also to be connected with low-impedance, i.e. “not isolated”. For this execution an additional, low-impedance connection with large-surface area between the machine ground and the housing of the peripheral device is to be provided (e.g. ground strap).
- Alternatively, e.g. on peripheral devices with an additional external power supply, the M12 plug connectors can be “isolated” from the housing ($\geq 1\text{M}\Omega$). The difference in potential between the machine ground and the GND of the peripheral devices must not exceed 3V.

The sketches below illustrate the different wiring concepts.

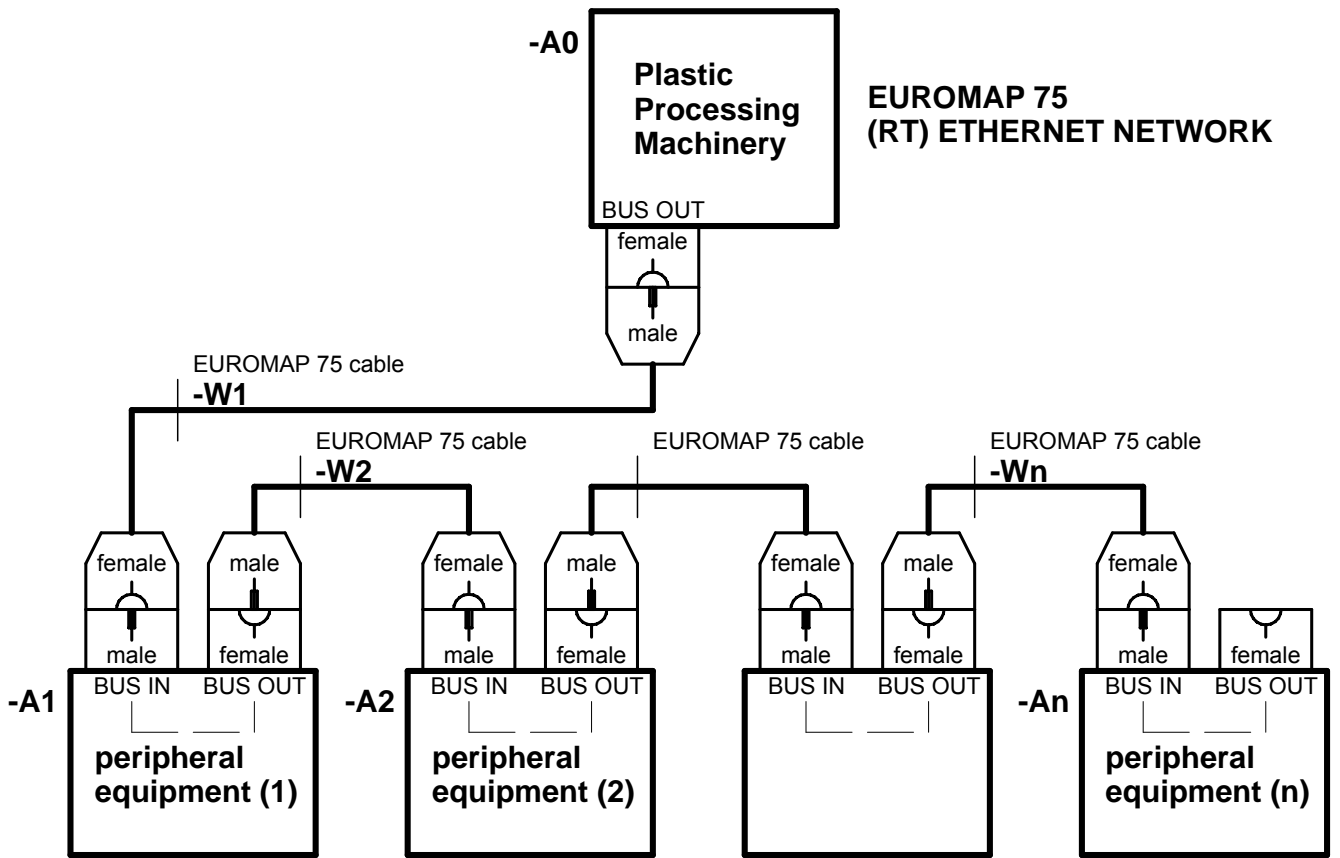

Figure 1: RT Network – Example of a line topology (daisy chain)

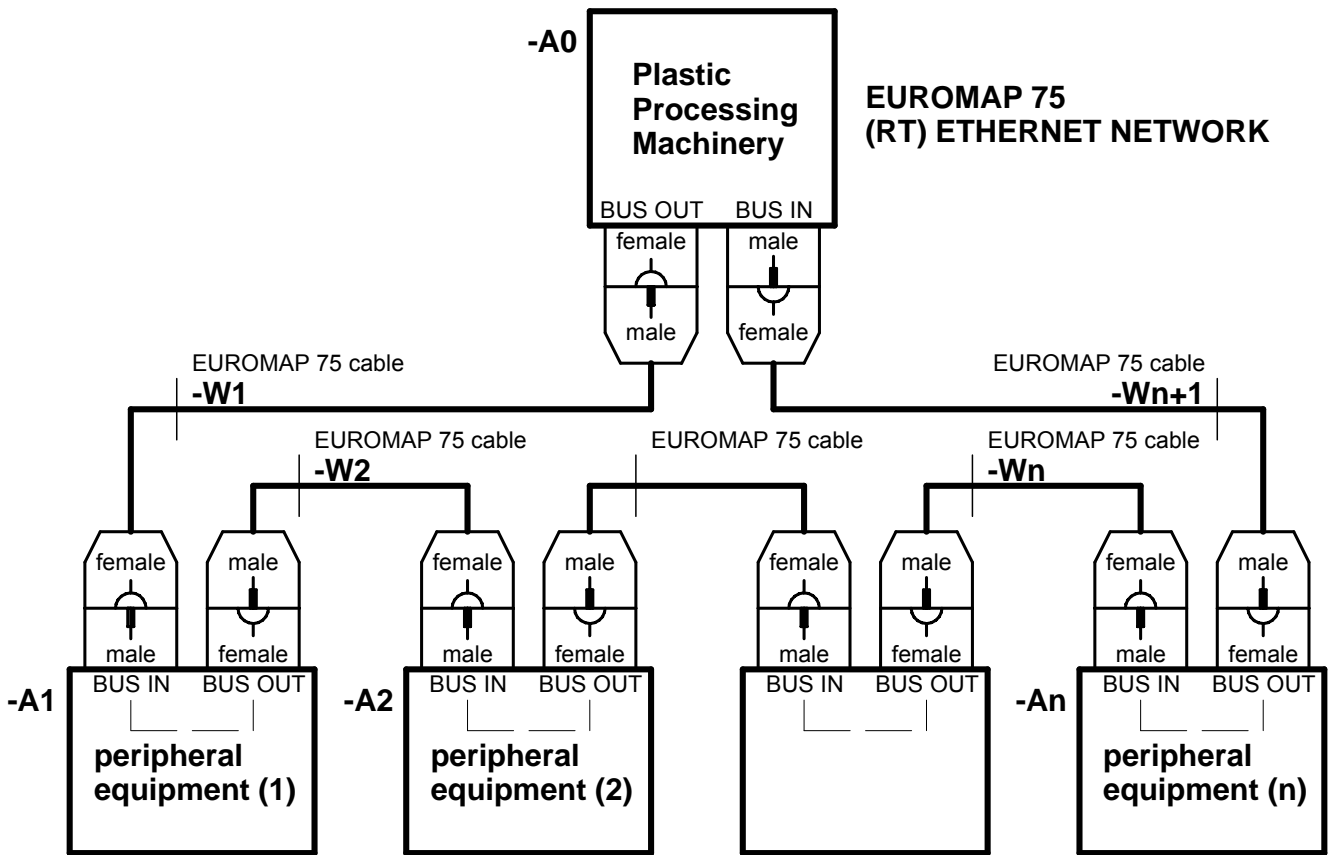

Figure 2: RT Network – Example of a ring topology

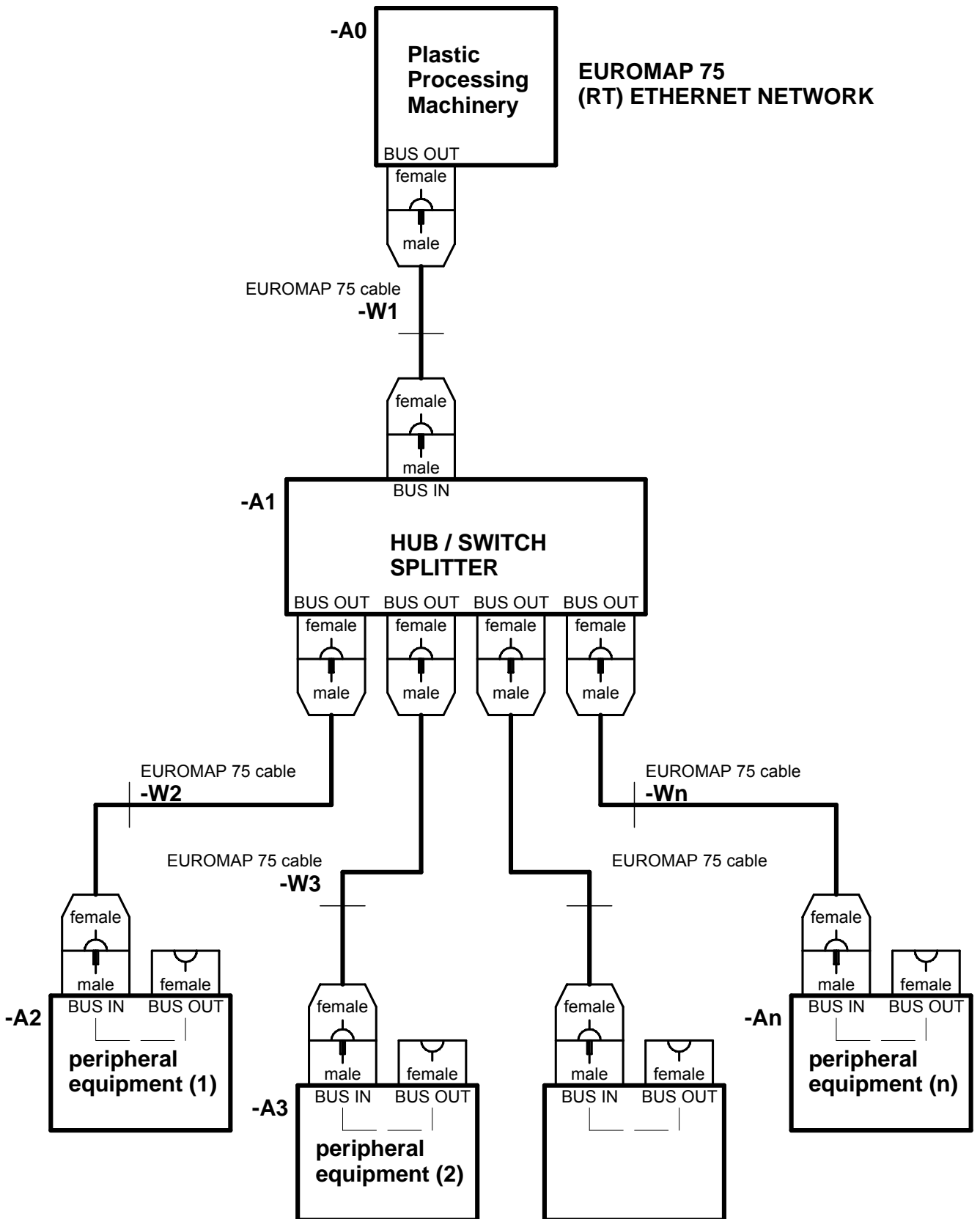

Figure 3: RT Network – Example of a star topology

2.2.2 EUROMAP 75 cable

The EUROMAP 75 cable is defined as follows:

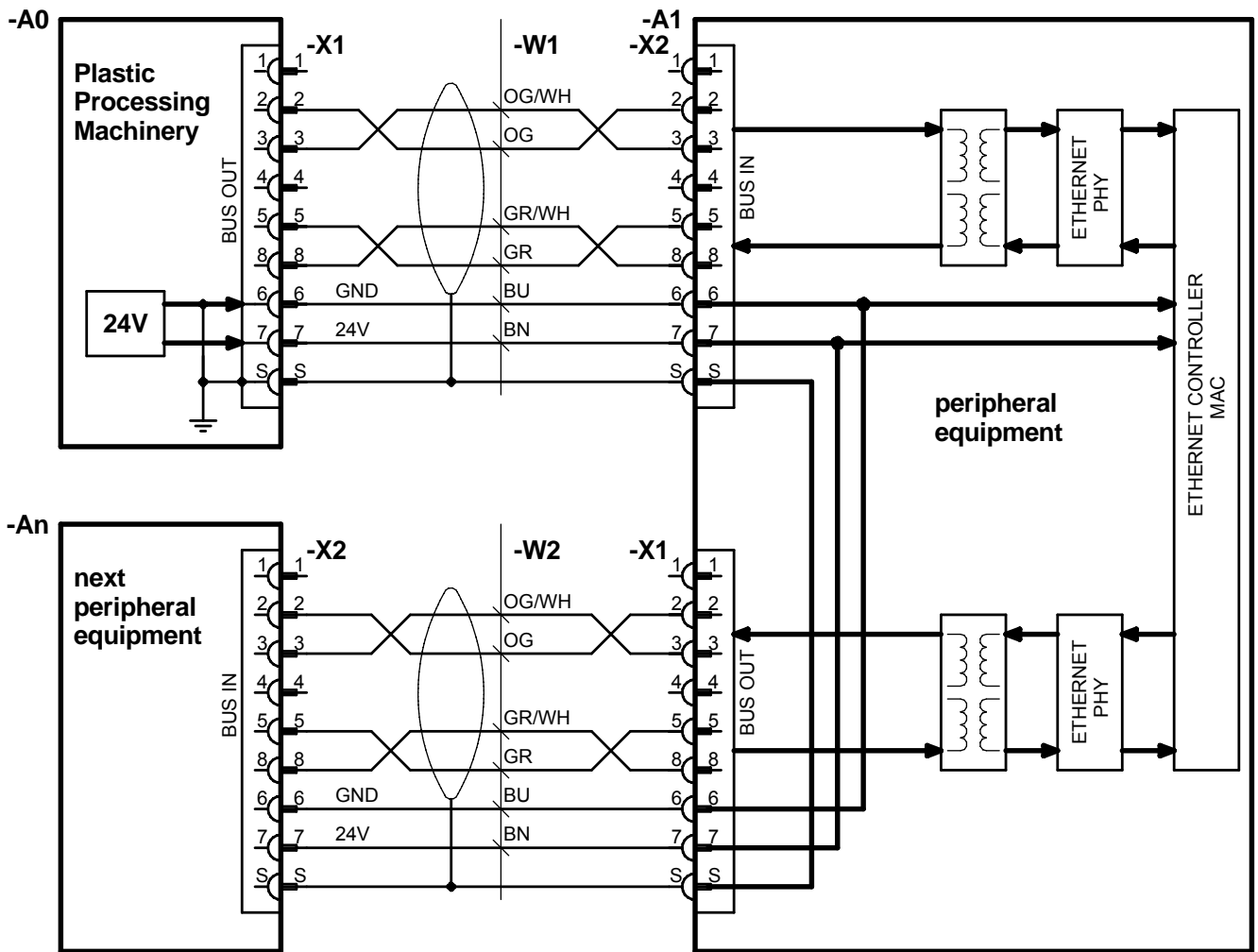

Figure 4: EUROMAP 75 cable – “isolated” wiring

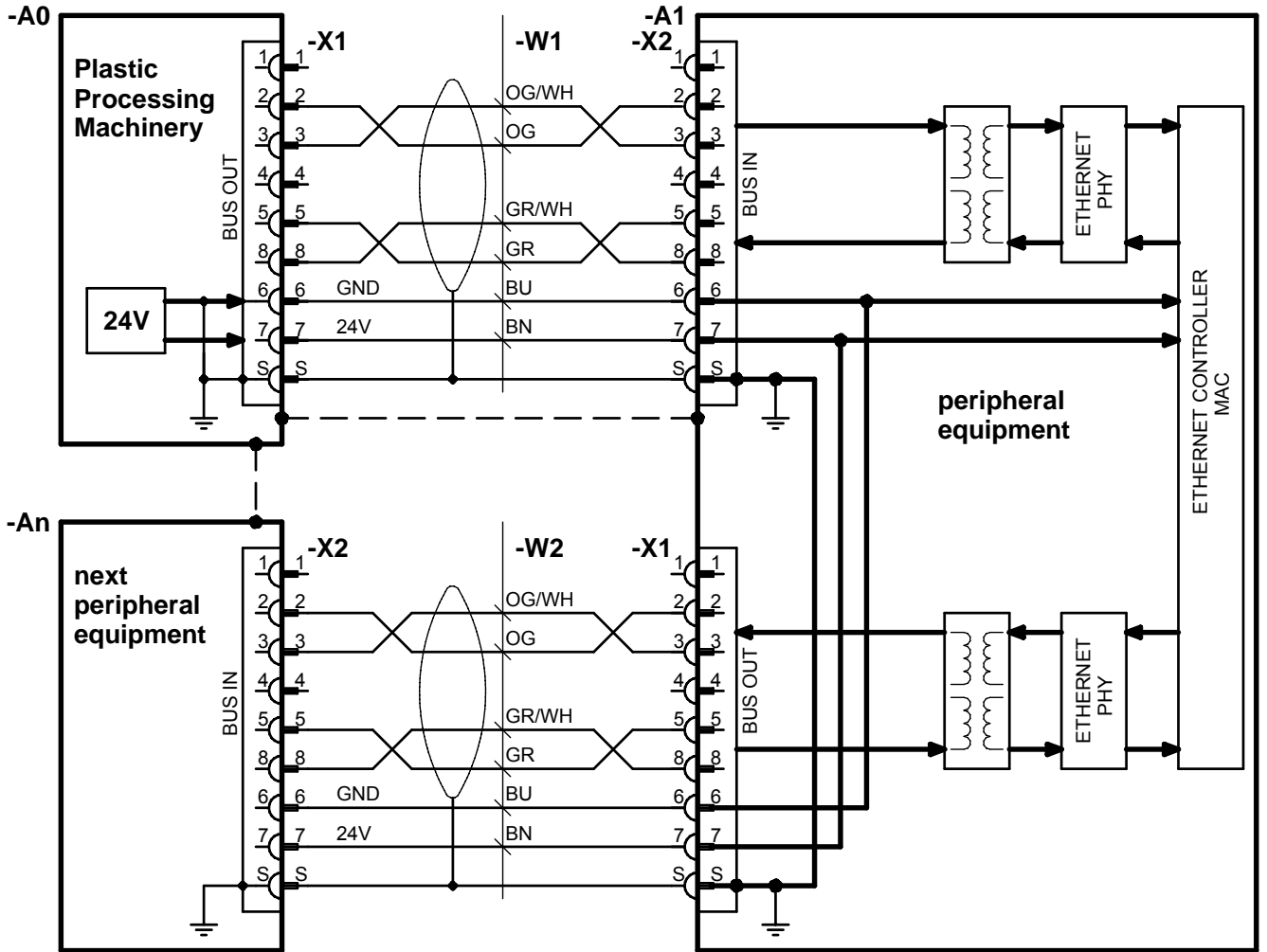

Figure 5: EUROMAP 75 cable – “not isolated” wiring

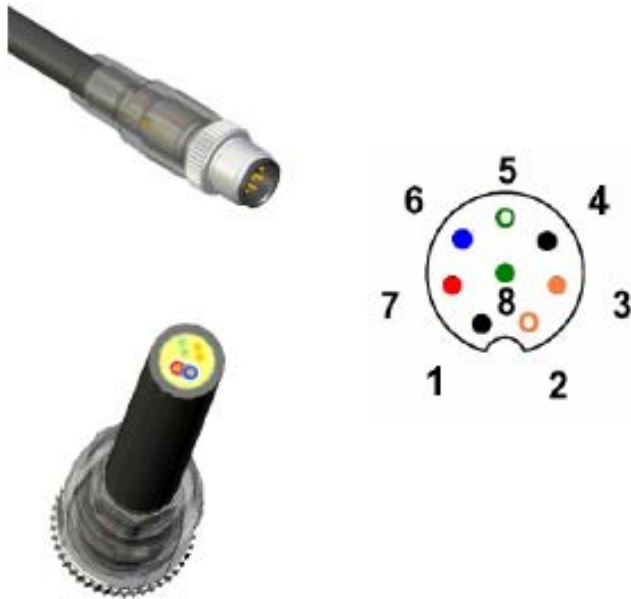

Figure 6: Example of a hybrid-cable

EUROMAP

Europäisches Komitee der Hersteller von Kunststoff- und Gummi-
maschinen

European Committee of Machinery Manufacturers for the Plastics
and Rubber Industries

Comité Européen des Constructeurs de Machines pour Plastiques
et Caoutchouc

Comitato Europeo Costruttori Macchine per Materie Plastiche e
Gomma

See you again

<http://www.euromap.org>

Copyright by EUROMAP