

**EUROMAP 27-1**

**Pipe and Profile Extrusion Lines**  
**Generic CANopen Interface**  
**Part 1: General definitions**

Version 3.2, January 2009  
(18 pages)

This recommendation was prepared by the Technical Commission of EUROMAP in cooperation with CiA.

An identical text is published under CiA 420-1 DS V3.0: "CANopen Profiles for Extruder Downstream Devices, Part 1: General definitions";

see also <http://www.can-cia.org/downloads/ciaspecifications/?2035>

**HISTORY**

<b>Date</b>	<b>Changes</b>
2002-10-22	<i>Publication of version 1.0</i>
2004-02-27	<i>Publication of version 2.0</i> Version 2.0 is not at all compatible to version 1.0
2007-04-12	<i>Publication of version 3.0</i> Editorial corrections and clarifications Calibration-table interface added Node-ID assignment recommendations added
2007-07-24	<i>Publication of version 3.1</i> Editorial corrections
2009-01-08	<i>Publication of version 3.2</i> Further supplier added

<b>CONTENTS</b>	<b>Page</b>
<b>1 Scope</b> .....	<b>4</b>
<b>2 Normative references</b> .....	<b>4</b>
<b>3 Abbreviations and definitions</b> .....	<b>4</b>
3.1 Abbreviations .....	4
3.2 Operating principles .....	4
3.2.1 Introduction.....	4
3.2.2 Physical layer definitions .....	7
<b>4 Error handling</b> .....	<b>12</b>
4.1 Principle .....	12
4.2 Error behavior .....	12
4.3 Emergency message .....	12
<b>5 Predefinitions</b> .....	<b>14</b>
5.1 Record definitions .....	14
5.1.1 Object 0080 <sub>h</sub> : Set process data .....	14
<b>5.2 Predefined communication objects</b> .....	<b>14</b>
5.2.1 Object 1000 <sub>h</sub> : Device type .....	14
5.2.2 Object 1001 <sub>h</sub> : Error register .....	15
5.2.3 Object 1005 <sub>h</sub> : COB-ID SYNC .....	15
5.2.4 Object 1006 <sub>h</sub> : Communication cycle period .....	15
5.2.5 Object 1014 <sub>h</sub> : COB-ID emergency object .....	16
5.2.6 Object 1016 <sub>h</sub> : Heartbeat consumer .....	16
5.2.7 Object 1017 <sub>h</sub> : Heartbeat producer .....	16
5.2.8 Object 1018 <sub>h</sub> : Identity .....	16
5.2.9 Object 1029 <sub>h</sub> : Error behavior .....	16
5.2.10 Object 67FF <sub>h</sub> : Device type.....	17

## 1 Scope

The CANopen application profile for extruder downstream devices includes several parts:

- Part 1 specifies general definitions
- Part 2 specifies the device profile for the puller downstream device
- Part 3 specifies the device profile for the corrugator downstream device
- Part 4 specifies the device profile for the saw downstream device
- Part 5 specifies the device profile for the co-extruder device
- Part 6 specifies the device profile for the calibration-table downstream device

This part specifies the physical layer and the common CANopen functions and common communication objects. It also specifies the CANopen functions of the extruder-master.

## 2 Normative references

- /CiA301/: CiA 301, CANopen application layer and communication profile
- /CiA302-1/: CiA 302-1, Additional CANopen application layer functions – Part 1: General definitions
- /CiA302-2/: CiA 302-2, Additional CANopen application layer functions – Part 2: Network management
- /CiA405/: CiA 405, CANopen interface and device profile for IEC 61131-3 programmable devices
- /EUROMAP28/: EUROMAP 28, Pipe and profile extrusion lines – Electrical interface for line speed detecting device (measuring wheel)
- /EUROMAP29/: EUROMAP 29, Pipe and profile extrusion lines – Discrete interface for downstream equipment after CANopen haul-off
- /EUROMAP66-1/: EUROMAP 66-1, Protocol for communication with peripheral equipment – Part 1: General description

## 3 Abbreviations and definitions

### 3.1 Abbreviations

Abbreviations given in /CiA301/ shall apply for this document as well.

### 3.2 Operating principles

#### 3.2.1 Introduction

All devices compliant with this application profile shall implement all mandatory communication services and protocols as well as all mandatory objects as specified in /CiA301/. The extruder downstream devices shall provide CANopen NMT-slave functionality; the master-extruder shall provide additionally CANopen NMT-master functionality as specified in /CiA302-1/ and in /CiA302-2/. It is not allowed to use this CANopen network for local sub-system communication purposes. All CANopen messages shall be transmitted with 11-bit identifiers only.

All devices compliant to this profile shall support heartbeat functionality; Node guarding shall not be supported. The device shall support heartbeat message transmissions from 100 ms to 1000 ms. Extruder downstream devices also shall produce the emergency message.

Extruder downstream devices shall support synchronous PDOs. They shall be able to support Sync cycle times of 20 ms.

It is not required that the extruder downstream devices support block or segmented SDO communication or Multiplexed PDO communication.

**3.2.1.1 Master-extruder**

The master-extruder shall implement NMT-slave functionality including the CANopen object dictionary. It may use the object dictionary entry range from 2000<sub>h</sub> to 5FFF<sub>h</sub> to implement the necessary application objects. Alternatively, the master-extruder may use the object dictionary range from A000<sub>h</sub> to AFFF<sub>h</sub>, if it is based on IEC 61131-3 programming languages and it is compliant to the definitions given in /CiA405/.

The master-extruder shall consume all heartbeats and emergency messages of the networked extruder downstream devices.

The master-extruder shall transmit the Sync message with a default period of 20 ms, periods of 40 ms and of 100 ms may be optionally supported.

**3.2.1.2 Puller downstream device**

The puller device is based on rolls, bands, or caterpillars. It requires a high-precise synchronous run with the master-extruder. Figure 1 shows the block diagram of the puller/master-extruder communication.

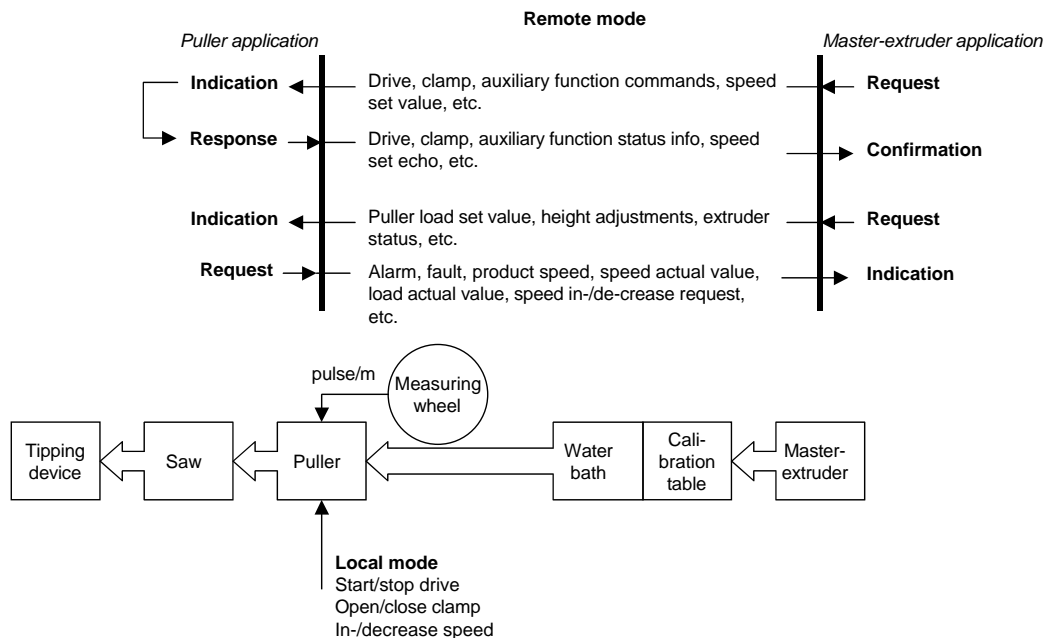

**Figure 1 — Puller and master-extruder block diagram**

**3.2.1.3 Corrugator downstream device**

The corrugator downstream device is used to produce structured wall pipes. Figure 2 shows the block diagram of the corrugator/master-extruder communication.

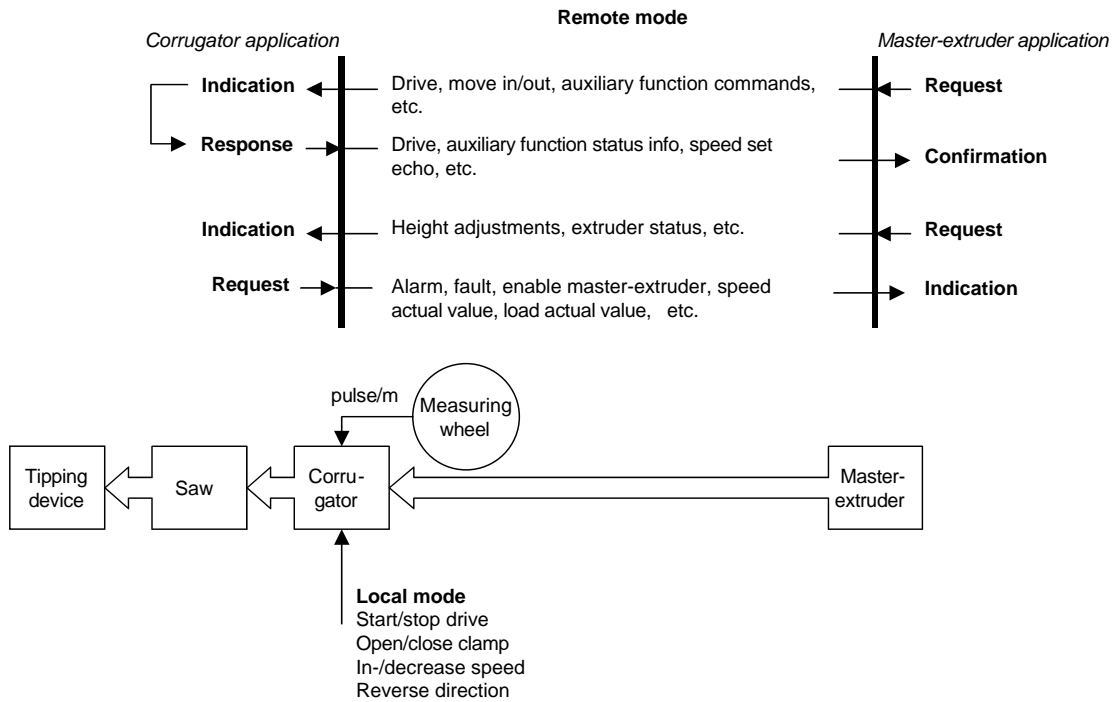

Figure 2 — Corrugator and master-extruder block diagram

3.2.1.4 Saw downstream device

The saw downstream device saws or cuts off the extruded profiles or pipes. Figure 3 shows the block diagram of the saw/master-extruder communication.

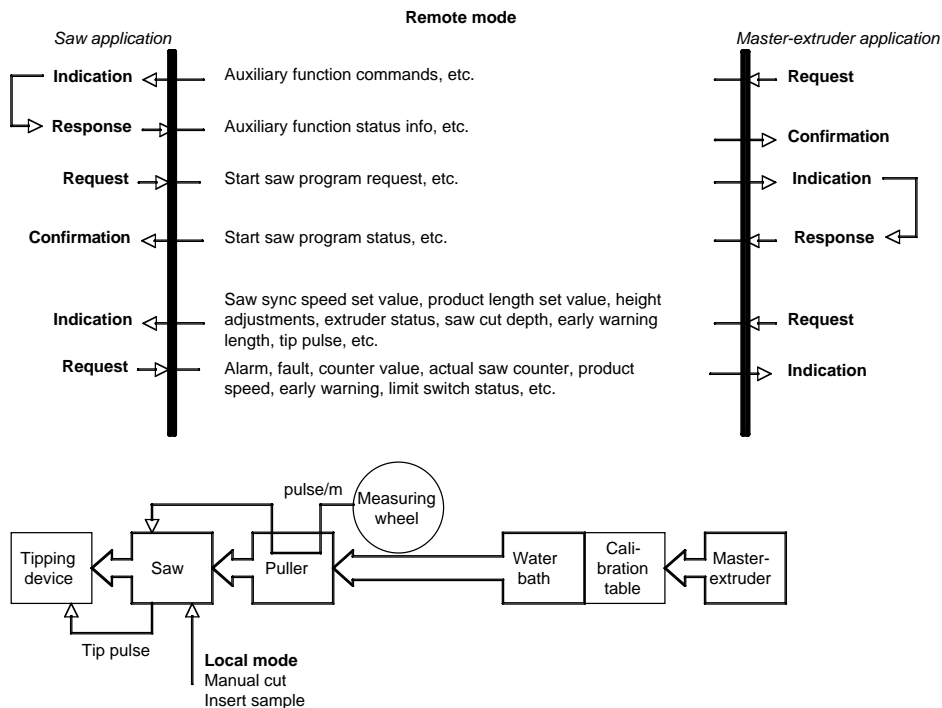
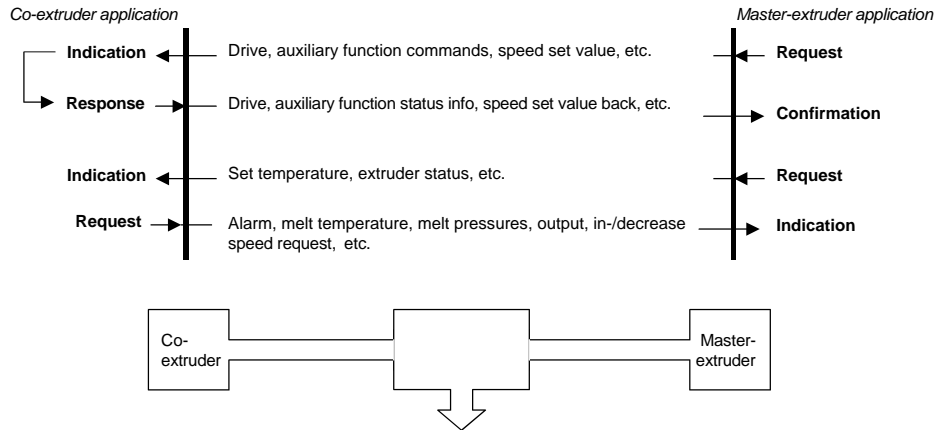

Figure 3 — Saw and master-extruder block diagram

**3.2.1.5 Co-extruder downstream device**

The co-extruder downstream device is necessary for example if different materials are used to produce a profile or pipe. Figure 4 shows the block diagram of the co-extruder/master-extruder communication.



**Figure 4 — Co-extruder and master-extruder block diagram**

**3.2.1.6 Calibration-table downstream device**

The calibration-table downstream device calibrates the profile or pipe. Figure 5 shows the block diagram of the calibration-table/master-extruder communication.

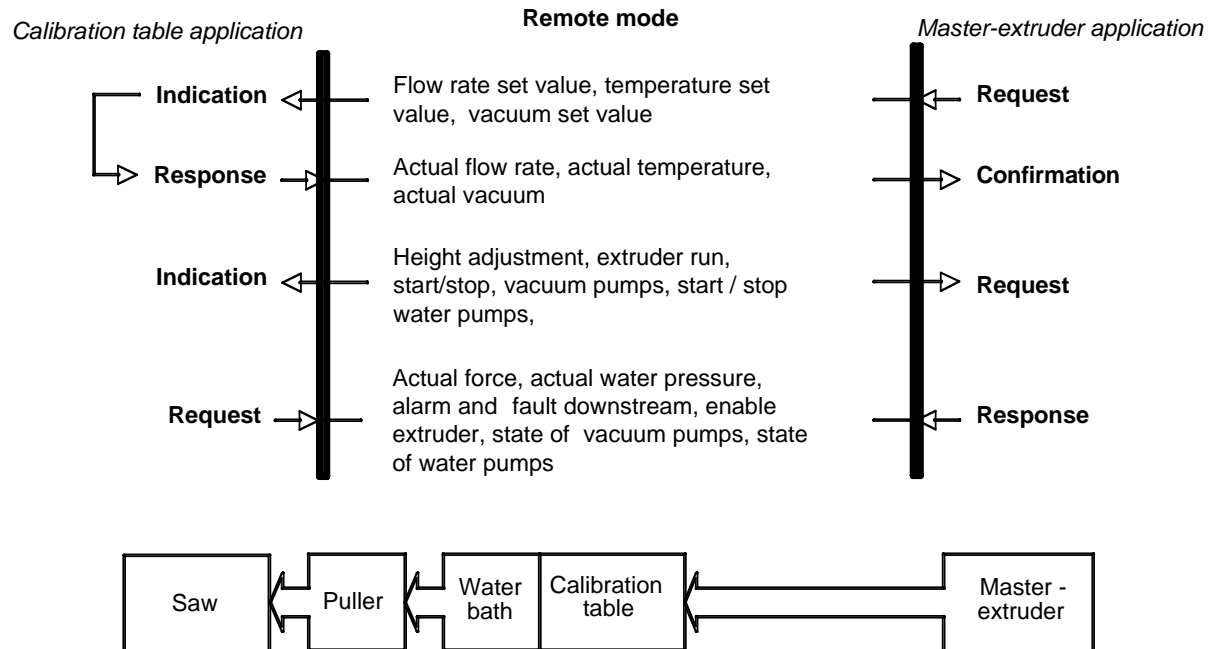

**Figure 5 — Calibration-table and master-extruder block diagram**

**3.2.2 Physical layer definitions**

**3.2.2.1 Hardware adjustments**

Bit-rates and node-ID shall be adjustable from outside via DIP-switches or local operator stations, adjustments via CANopen or programming tools are not allowed. The default bit-rate

shall be 250 kbit/s, optional bit-rates are 125 kbit/s and 500 kbit/s. The maximum network length is specified in /CiA301/.

### 3.2.2.2 Node-ID range

The recommended assignment of node-IDs is shown in Table 1. In case of multiple CANopen logical devices, it is recommended to use the first CANopen logical device to assign the node-ID.

**Table 1 — Recommended node-ID assignment**

Node-ID range	Device
1	Master-extruder
2 to 16	Co-extruder 1 to 15
17 to 24	Calibration-table 1 to 8
25 to 32	Puller 1 to 8
33 to 40	Corrugator 1 to 8
41 to 48	Saw 1 to 8

### 3.2.2.3 Termination resistor

The default termination resistor shall be 120 Ohm.

### 3.2.2.4 Cable definition

The used cables shall be compliant to /EUROMAP66-1/ (see clause 3.1). The schematic connection order of the devices shall be as shown in Figure 6.

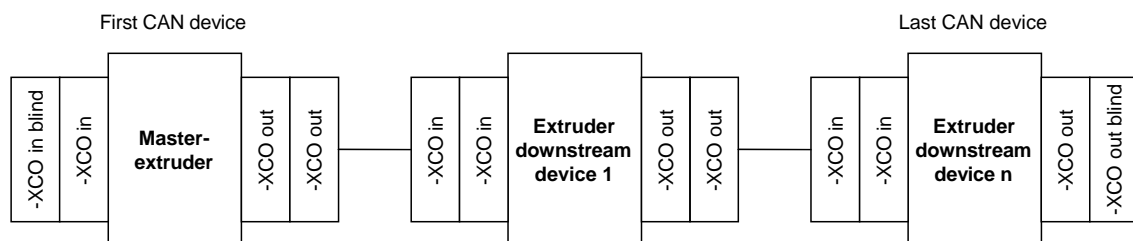

**Figure 6 — Schematic connection order of master-extruder and downstream devices**

### 3.2.2.5 Connector definition

For -XCO in and -XCO out the Han Quintax connector from Harting or a compatible connector shall be used. Table 2 to Table 5 show the connector elements and the ordering numbers.

#### Suppliers:

HARTING Electric GmbH & Co. KG  
 Wilhelm-Harting-Str. 1  
 32339 Espelkamp/GERMANY  
<http://www.harting.com>

I.L.M.E SPA  
 Via Marco Antonio Colonna 9  
 20149 Milano/ITALY  
<http://www.ilme.com>

**Table 2 — Device “input” cable with socket connector or blind plug**

Connector element	No. of pieces	Harting order no.	ILME order no.
Housing	1	19300100427	MAV 10.32
Frame	1	09140100313	CX 03 TF
CAN holder	1	09140023101	CX 02 BF
CAN insert	1	09150043113	CX 04 BF
Insert	1	09140083101	CX 08 CF
CAN pins	4	09150006203	CDFA 0.5
Pins	8	09330006204	CCFA 1.5

**Table 3 — Device “input” socket connector with interlock**

Connector element	No. of pieces	Harting order no.	ILME order no.
Housing	1	09300100301	CHI 10
Frame	1	09140100303	CX 03 TM
CAN holder	1	09140023001	CX 02 BM
CAN insert	1	09150043013	CX 04 BM
Insert	1	09140083001	CX 08 CM
CAN pins	4	09150006103	CDMA 0.5
Pins	8	09330006104	CCMA 1.5

**Table 4 — Device “output” socket connector**

Connector element	No. of pieces	Harting order no.	ILME order no.
Housing	1	09300100310	CHI 10 C-1
Frame	1	09140100313	CX 03 TF
CAN holder	1	09140023101	CX 02 BF
CAN insert	1	09150043113	CX 04 BF
Insert	1	09140083101	CX 08 CF
CAN pins	4	09150006203	CDFA 0.5
Pins	8	09330006204	CCFA 1.5

**Table 5 — “Output” cable with plug connector or blind plug with interlock**

Connector element	No. of pieces	Harting order no.	ILME order no.
Housing	1	19300100737	MAV 10 G32
Frame	1	09140100303	CX 03 TM
CAN holder	1	09140023001	CX 02 BM
CAN insert	1	09150043013	CX 04 BM
Insert	1	09140083001	CX 08 CM
CAN pins	4	09150006103	CDMA 0.5
Pins	8	09330006104	CCMA 1.5

Figure 7 specifies the connector pinning.

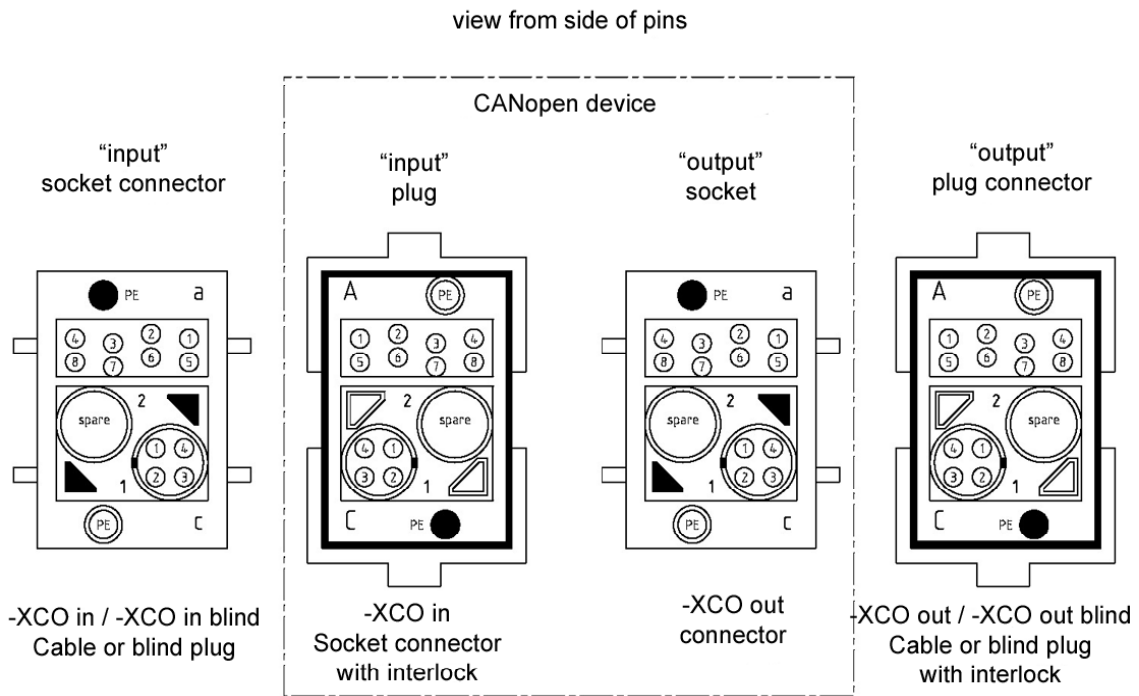

**Figure 7 — Pinning of the plug and socket connector**

### 3.2.2.6 Emergency-stop wiring

The emergency-stop wiring is specified in Figure 8.

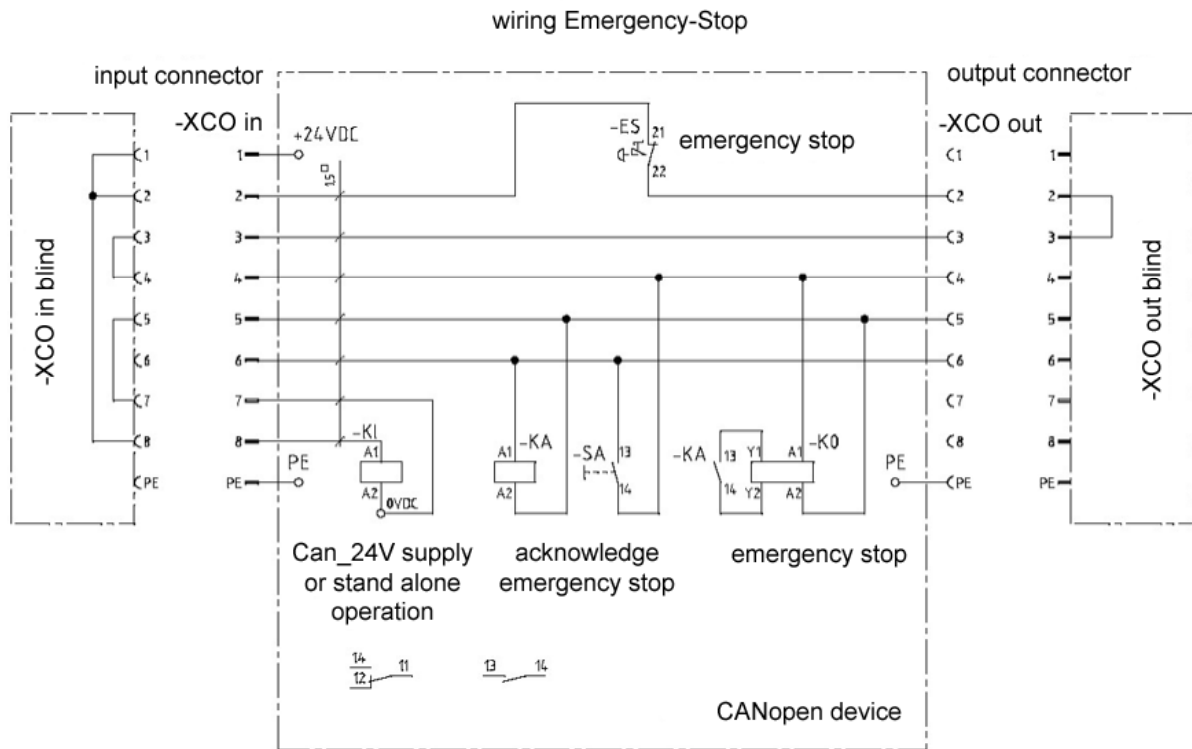

**Figure 8 — Emergency-stop wiring**

**3.2.2.7 CAN bus line wiring**

Figure 9 specifies the CAN bus wiring and Table 6 illustrates the recommended line colors. It is recommended to use 2 x 2 x 0,34 mm<sup>2</sup> bus-lines.

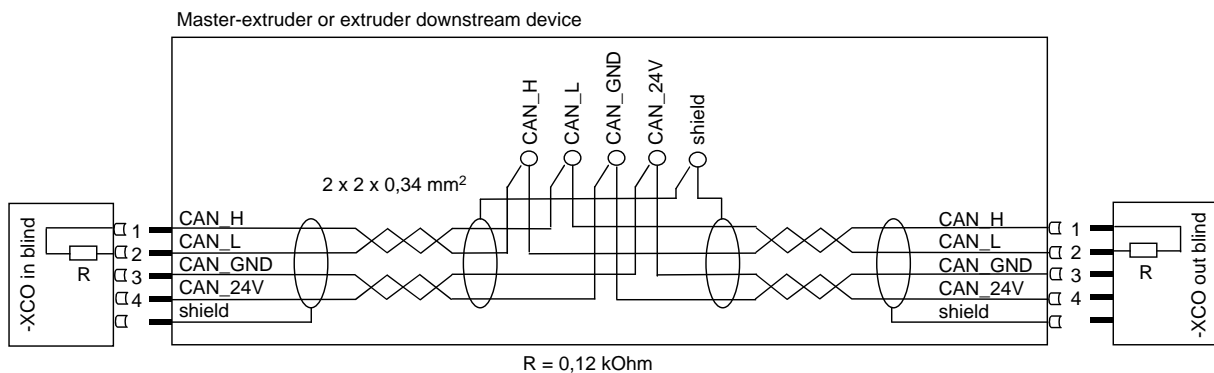

**Figure 9 — CAN bus line wiring**

**Table 6 — Line color recommendation**

Line	Color
CAN_H	Yellow
CAN_L	Green
CAN_GND	Brown
CAN_24V	White

**3.2.2.8 Additional discrete measuring wheel interface wiring**

If a measuring wheel is used it shall be wired as specified in /EUROMAP28/.

### 3.2.2.9 Additional discrete interface wiring

If a non-CAN interface to a saw or another device is needed it shall be wired as specified in /EUROMAP29/.

## 4 Error handling

### 4.1 Principle

Emergency messages shall be triggered by internal errors in the device and they are assigned the highest possible priority to ensure that they get access to the bus without latency. By default, the Emergency messages shall contain the error field with pre-defined error numbers and additional information.

### 4.2 Error behavior

If a severe device failure is detected the module shall enter by default autonomously the pre-operational state. If object 1029<sub>h</sub> is implemented, the device can be configured to enter alternatively the stopped state or remain in the current state in case of a device failure. Device failures shall include the following communication errors:

- Bus-off conditions of the CAN interface
- Life guarding event with the state 'occurred'
- Heartbeat event with state 'occurred'

Severe device errors also may be caused by device internal failures.

### 4.3 Emergency message

Figure 10 specifies the emergency message structure and Figure 11 specifies the manufacturer-specific error byte (MEB). The emergency error code (EEC) and the error register (ER) are specified in /CiA301/.

**Figure 10 — Emergency message structure**

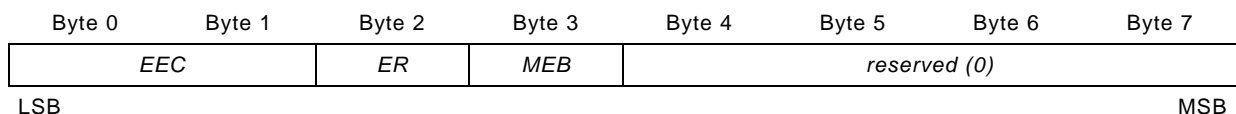

**Figure 11 — Manufacturer-specific error byte structure**

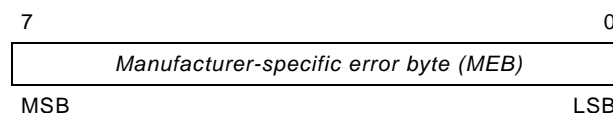

Table 7 specifies the additional emergency error codes. If an alarm occurs, the production will be continued, at fault the production shall stop.

**Table 7 — Emergency error code definitions**

EEC	Definition
FF10 <sub>h</sub>	Internal puller alarm
FF11 <sub>h</sub>	Internal puller fault
FF20 <sub>h</sub>	Internal corrugator alarm

EEC	Definition
FF21 <sub>h</sub>	Internal corrugator fault
FF30 <sub>h</sub>	Internal saw alarm
FF31 <sub>h</sub>	Internal saw fault
FF40 <sub>h</sub>	Internal co-extruder alarm
FF41 <sub>h</sub>	Internal co-extruder fault
FF50 <sub>h</sub>	Internal calibration-table alarm
FF51 <sub>h</sub>	Internal calibration-table fault

The manufacturer-specific error byte codes are specified in Table 8.

**Table 8 — Manufacturer-specific error byte definition**

MEB code	Definition
0 <sub>d</sub>	Generic error
1 <sub>d</sub>	Emergency stop
2 <sub>d</sub>	Safety door(s) open
3 <sub>d</sub>	Drive(s) failure
4 <sub>d</sub>	Motor(s) temperature high
5 <sub>d</sub>	Motor fan(s)
6 <sub>d</sub>	Cabinet fan
7 <sub>d</sub>	Lubrication system
8 <sub>d</sub>	Exhaust unit
9 <sub>d</sub>	Air pressure
10 <sub>d</sub>	Vacuum system
11 <sub>d</sub>	Cooling system
12 <sub>d</sub>	Chain break control
13 <sub>d</sub>	Power supply
14 <sub>d</sub>	Cut not completed
15 <sub>d</sub>	Line speed too high
16 <sub>d</sub>	Limit switch measuring wheel
17 <sub>d</sub>	Min. process temperature
18 <sub>d</sub>	Max. process temperature
19 <sub>d</sub>	Min. process pressure
20 <sub>d</sub>	Max. process pressure
21 <sub>d</sub>	Height adjustment
22 <sub>d</sub>	Lateral adjustment
23 <sub>d</sub>	Traverse unit
24 <sub>d</sub>	Material in return travel
25 <sub>d</sub>	Max. motor load
26 <sub>d</sub>	Measuring wheel not on product
27 <sub>d</sub> to 255 <sub>d</sub>	reserved

## 5 Predefinitions

### 5.1 Record definitions

#### 5.1.1 Object 0080<sub>h</sub>: Set process data

Table 9 specifies the record structure. Figure 12 specifies the structure and Table 10 defines the value of the *controller on/off* sub-object. The values of the *set process data 1* to *10* sub-objects are defined in the objects using this data type.

**Table 9 — Record structure**

Sub-index	Parameter	Data type
00 <sub>h</sub>	Highest sub-index supported	Unsigned8
01 <sub>h</sub>	Controller on/off	Unsigned16
02 <sub>h</sub>	Set process data 1	Integer16
03 <sub>h</sub>	Set process data 2	Integer16
04 <sub>h</sub>	Set process data 3	Integer16
05 <sub>h</sub>	Set process data 4	Integer16
06 <sub>h</sub>	Set process data 5	Integer16
07 <sub>h</sub>	Set process data 6	Integer16
08 <sub>h</sub>	Set process data 7	Integer16
09 <sub>h</sub>	Set process data 8	Integer16
0A <sub>h</sub>	Set process data 9	Integer16
0B <sub>h</sub>	Set process data 10	Integer16

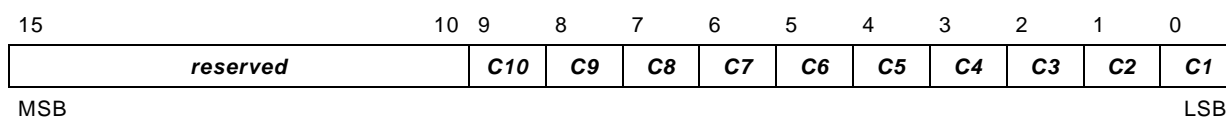

**Figure 12 — Controller on/off structure**

**Table 10 — Value definition for controller on/off**

Signal	Value	Definition
<i>C1</i> to <i>C10</i> ( <i>controller 1</i> to <i>10</i> )	0 <sub>b</sub> 1 <sub>b</sub>	Controller off Controller on

### 5.2 Predefined communication objects

#### 5.2.1 Object 1000<sub>h</sub>: Device type

This object shall provide the type of device and its functionality. For multiple CANopen logical devices the additional information parameter shall contain FFFF<sub>h</sub>. In this case, the object 67FF<sub>h</sub> shall be implemented.

Multiple CANopen logical devices shall be only allowed for puller or corrugator as first logical device with one saw as second logical device.

Figure 13 specifies the object structure. The device profile number shall be 420<sub>d</sub>. Table 11 specifies the device class codes. Table 12 specifies the specific functions for master-extruder. Table 13 specifies the specific functions for co-extruder downstream device. Table 14 specifies the specific functions other downstream devices such as puller, corrugator saw, and calibration-table.

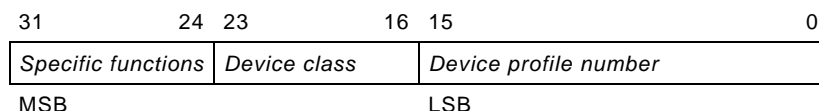
**Figure 13 — Object structure****Table 11 — Device class definition**

Code	Function
00 <sub>h</sub>	Master-extruder
01 <sub>h</sub>	Puller
02 <sub>h</sub>	Corrugator
03 <sub>h</sub>	Saw
04 <sub>h</sub>	Co-extruder
05 <sub>h</sub>	Calibration-table
06 <sub>h</sub> to FE <sub>h</sub>	reserved

**Table 12 — Specific functions for master-extruder**

Code	Function
00 <sub>h</sub>	reserved
01 <sub>h</sub>	Not compliant to /CiA405/
02 <sub>h</sub>	Compliant to /CiA405/
03 <sub>h</sub> to FE <sub>h</sub>	reserved

**Table 13 — Specific functions for co-extruder downstream device**

Code	Function
00 <sub>h</sub>	reserved
01 <sub>h</sub>	Simple co-extruder
02 <sub>h</sub>	Advanced co-extruder
03 <sub>h</sub> to FE <sub>h</sub>	reserved

**Table 14 — Specific functions for other downstream devices**

Code	Function
00 <sub>h</sub> to FE <sub>h</sub>	reserved

**5.2.2 Object 1001<sub>h</sub>: Error register**

This object provides the error register as specified in /CiA301/. It is a part of the emergency message. The device profile specific bit shall be not used.

**5.2.3 Object 1005<sub>h</sub>: COB-ID SYNC**

This object shall be implemented. It is specified in /CiA301/. The CAN-ID shall not be changed.

**5.2.4 Object 1006<sub>h</sub>: Communication cycle period**

The master-extruder device shall implement this object. It is specified in /CiA301/.

### 5.2.5 Object 1014<sub>h</sub>: COB-ID emergency object

This object shall be implemented. It is specified in /CiA301/. The CAN-ID shall not be changed.

### 5.2.6 Object 1016<sub>h</sub>: Heartbeat consumer

The master-extruder device shall implement this object. It is specified in /CiA301/.

### 5.2.7 Object 1017<sub>h</sub>: Heartbeat producer

All devices compliant to this profile shall implement this object. It is specified in /CiA301/. The default value shall be between 100<sub>d</sub> and 1000<sub>d</sub>.

### 5.2.8 Object 1018<sub>h</sub>: Identity

This object provides general information about the device as specified in /CiA301/.

The manufacturer-specific revision number (sub-index 03<sub>h</sub>) consists of a major revision number and a minor revision number. The major revision number identifies a specific CANopen behavior. If the CANopen functionality is expanded, the major revision shall be incremented. The minor revision number identifies different versions with the same CANopen behavior.

The revision number (sub-index 03<sub>h</sub>) is mandatory and shall indicate the supported profile version. Figure 14 specifies the structure of the revision number. The minor revision number and the major revision number lower byte are manufacturer-specific. The values for the major revision higher byte are specified in Table 15.

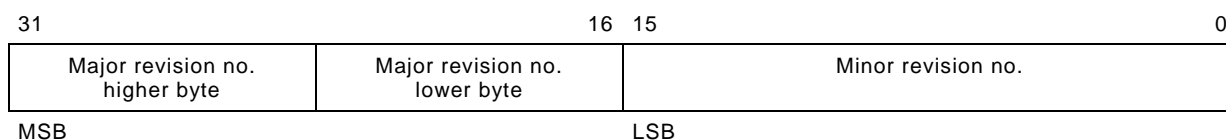

**Figure 14 — Structure of revision number**

**Table 15 — Value definition for the higher byte of mayor revision number**

Value [hex]	Definition
1	Compliant to version 1.0
2	Compliant to version 2.0
3	Compliant to version 3.0
Other values shall be reserved.	

### 5.2.9 Object 1029<sub>h</sub>: Error behavior

This object specifies to which state the device shall be set, in case a communication error or a device-internal error is detected. It is specified in /CiA301/. Table 16 defines the values. Table 17 specifies the object description and Table 18 specifies the entry description.

**Table 16 — Value definition**

Value [hex]	State transition
0	NMT pre-operational (only if current state is operational)
1	No state change
2	NMT stopped
Other values shall be reserved.	

**Table 17 — Object description**

Attribute	Value
Index	1029 <sub>h</sub>
Name	Error behavior
Object code	Array
Data type	Unsigned8
Category	Optional

**Table 18 — Entry description**

Attribute	Value
Sub-Index	00 <sub>h</sub>
Description	Number of error classes
Access	const
Entry category	Mandatory
PDO mapping	No
Value range	02 <sub>h</sub>
Default value	02 <sub>h</sub>
Sub-index	01 <sub>h</sub>
Description	Communication error
Access	rw
Entry category	Mandatory
PDO mapping	No
Value range	00 <sub>h</sub> to 02 <sub>h</sub>
Default value	00 <sub>h</sub>
Sub-index	02 <sub>h</sub>
Description	Internal device error
Access	rw
Entry category	Mandatory
PDO mapping	No
Value range	00 <sub>h</sub> to 02 <sub>h</sub>
Default value	00 <sub>h</sub>

**5.2.10 Object 67FF<sub>h</sub>: Device type**

This objects shall describe the first virtual device in a multiple device module according to /CiA301/.

## **EUROMAP**

Europäisches Komitee der Hersteller von Kunststoff- und Gummimaschinen

European Committee of Machinery Manufacturers for the Plastics and Rubber Industries

Comité Européen des Constructeurs de Machines pour Plastiques et Caoutchouc

Comitato Europeo Costruttori Macchine per Materie Plastiche e Gomma

**See you again**

**<http://www.EUROMAP.org>**